



**Miss Rodeo Nevada LIW 2026
PARTICIPANT RULES AND REGULATIONS
July 31 – August 2, 2025
South Point Hotel & Casino
Application Due –midnight, June 30th, 2025**

GENERAL RULES OF THE PAGEANT: Application due midnight, June 30, 2025.

Note: The MRNA Board of Directors will provide Participant with a room, that may or may not be a shared room with another Participant.

1. Participant will be 21 years of age by November 1, 2026. I will be no older than 26 years of age as of December 31, 2026. Upon request, participant will provide a copy of a government issued identification (such as a birth certificate, driver's license, passport, etc.) verifying age.
2. **Residency Requirements**
 - Participant is a United States Citizen. _____ initial
 - Participant has been a resident of the state of Nevada at least 3 months prior to the **application submission deadline** of the Miss Rodeo Nevada Pageant. _____ initial
 - Proof of residency must include a valid Nevada Driver's License issue date no less than 3 months prior to the **application submission deadline** of the pageant. _____ initial
 - The participant has not competed in any other Miss Rodeo State pageant which is affiliated with the Miss Rodeo America, Inc organization **within 6 months prior to the application submission deadline** of the Miss Rodeo Nevada Pageant. _____ initial
 - I will maintain my residency in the State of Nevada for the entirety of my reign including my reign as Miss Rodeo Nevada Lady in Waiting. _____ initial

Miss Rodeo Nevada Association reserves the right to alter these requirements.
3. Judges will be selected by the MRNA Board of Directors.
4. The Pageant will be judged by no less than three judges.
5. All scoring is turned over to a designated Pageant Auditor. All Participants evaluation sheets will be returned to them.
6. Participant is required to attend the Pageant Orientation and will provide their own transportation to the host hotel on the first day of the Pageant.
7. Participant will be provided transportation to and from the Pageant activities.
8. Orientation may consist of the following:
 - a) An opportunity to meet the Participants, their parents and the MRN Board of Directors.
 - b) A description of Pageant activities with the opportunity to ask questions and receive answers about those activities.
 - c) Drawing for the order of the Participant's appearances in all Pageant activities.
9. Participant must provide their own wardrobe and follow the Wardrobe Guidelines & Dress Code.
10. Participant will not be permitted to drink alcoholic beverages, use any tobacco, marijuana, illegal substances, inappropriate language or participate in inappropriate internet or social networking behavior at any time during the Pageant or during her reign if chosen as the titleholder.
11. Participant must conduct themselves in a proper, ladylike manner and portray integrity and ethical standards. Actions of un-sportsmanship like conduct will not be tolerated.

12. Participant, and individuals related to a Participant, may not contact judges before, during, or after the Pageant. Action of this type can result in disqualification of the Participant at the discretion of the MRNA Board of Directors. Any contact with Participant must be through the chaperone.
13. Participant may not leave the MRN Pageant until the Participants have checked out with the designated MRN Board of Directors Member. Until checked out, all Participants must abide by Pageant rules. Failure to comply with this provision could jeopardize future eligibility, current runner-up status and/or awards.
14. The possession of and/or use of any electronic devices such as cell phones, laptop computers, and/or any devices with internet capabilities are strictly prohibited by Participants during the competition. In case of emergency, all inquiries must go through the chaperone.
15. The MRNA Board of Directors reserves the right to alter any rule and has the sole authority over any rule discrepancy. If any rules are altered, Participants will be notified that changes have been made as soon as possible.
16. If a Participant fails to arrive on time for any Pageant event she may be penalized and or disqualified at the MRNA BOARD of Director's discretion.
17. Piercings are not permitted. Pierced earrings may be worn. No more than one (1) pair of earrings may be worn at any time and NEVER above the ear lobe. There will be no visible body piercings at any time.
18. There will be no visible tattoos displayed at any time. If you do have tattoos, they must be covered at all times.
19. Additional information is available in the Wardrobe Guideline.

Initial

PAGEANT DIVISIONS:

Four (4) judge comment divisions:

- Personality
- Appearance
- Horsemanship
- Knowledge

Written Test

The purpose of the following is to evaluate Participant:

PERSONALITY:

1. Intelligence and common sense.
2. Conversational ability in varied situations with an emphasis on correct grammar and enunciation.
3. A sense of humor.
4. Self-confidence, sincerity, and integrity.

5. Self-projection – the ability to project one's personality in any situation
6. Positive outlook on life.
7. Genuine interest in other people and noticeable consideration of others.
8. Professionalism.
9. Promptness and cooperation.
10. Maturity.

APPEARANCE:

1. Attractiveness, charm, radiates self-confidence and maturity.
2. Grooming: meticulous care in neatness and cleanliness, such as: complexion, hands, fingernails, makeup, hair.
3. Posture: This should include carrying oneself straight and tall with self-confidence and poise.
4. Poise and ladylike behavior in every situation: this should include handling every type of situation with grace, style and proper etiquette.
5. Photogenic quality.
6. Western fashion sense: Participants should be aware of what is currently fashionable and trends in western wear industry and western wear sponsors of MRN, MRA and the PRCA.
7. Proper fit of clothing: this includes figure - flattering styles altered for a personal fit. Properly fitted and shaped hats, which flatter the Participant's face, will be considered. Judges will look for versatility and imagination in the Participant's ability to carry out a "total look."
8. Judges will be looking for versatility and imagination which enhance the Participant's personal features. Attention will be paid to suitability of the outfit to the judged event.

HORSEMANSHIP:

1. Control of mount, proper arena etiquette, and the way each situation that may occur is handled.
2. Balance, ability, and position of hands, feet, and seat when riding at a reasonable rate of speed for the activity.
3. Precise execution of patterns and understanding the leads.
4. Mounting and dismounting.

5. Confidence, appearance and awareness of audience.
6. Presentation ride (Queens Run/Wave).
7. Knowledge of horsemanship and horse science.
8. Participant's ability to project her personality to the audience from horseback.

General Rules Horsemanship:

1. The understanding and skill of the Participant will be judged and **not the horse or the equipment**.
2. Participant will be provided horses and western style saddle/tack.
3. Participant will ride with the tack provided. Any changes required will be determined by the judges. Judges will review tack during the warm-up period and determine suitability of tack to Participant.
4. Participant will not wear spurs or chaps.
5. Participant must make sure their hats stay securely on their heads.
6. Judges may elect to require the Participant to perform any other horsemanship related task they deem relevant.
7. Re-rides are at the sole discretion of the judges.
8. Judges have the right to ask Participant questions during the Horsemanship Competition. Judges may talk to Participant, or ask horsemanship questions in the arena, on stage, during public appearances and/or during interviews.
9. Participant will ride with one hand on the reins.
10. Participant may be asked to carry a flag.
11. Required attire for Horsemanship is in the Wardrobe Guidelines.
12. Other arena work may be requested at the discretion of the MRNA Board of Directors and/or judges.
13. The following categories may be used for Horsemanship interview topics: Knowledge of tack, horse science (including feeding, grooming, and parts of the horse), PRCA rodeo, history of rodeo, rodeo terminology, explanation of standard rodeo events, championship rodeo standings, current rodeo issues as well as other horsemanship and rodeo topics deemed important by the judges and/or the MRN Board of Directors.
14. There will be two rounds of competition. Prior to the start of the competition, horses will be drawn. Participant will ride a different horse for each round of horsemanship competition. Every element of the Horsemanship portion of the Pageant will be scored regardless of the execution of set pattern. Failure to execute the set pattern will not constitute disqualification of Participant. First Round: The first round will consist of riding one of the 3 patterns provided in the Rules and Regulations, chosen by the judges. The participants will be notified of which pattern was chosen during orientation.
The pattern chosen by the judges will be demonstrated.

Second Round:

• It will be a 1 ½ minute freestyle pattern. Time starts when the shoulder of the horse crosses the plane of the gate. It must include, but not limited to, the following 4 elements in any order.

- Lead change
- Presentation run
- Back
- Stop

Judges may, at their discretion, deduct points if they see or hear trainers and/or parents coaching Participant.

Initial

Pattern 1

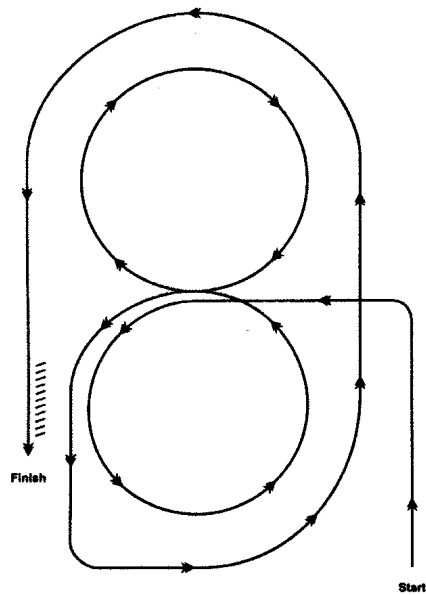

Horseman Pattern 1:

1. Do extended jog along side of arena, then to center
2. Begin lope at center of arena and lope left circle on left lead
3. Change leads at center of arena and lope right circle on right lead
4. Change leads and continue loping around end of arena
5. Once on the straight, increase speed and continue around end of arena
6. Stop and back
7. The Judges Committee reserves the right to make alterations and/or additions to this pattern.

Pattern 2

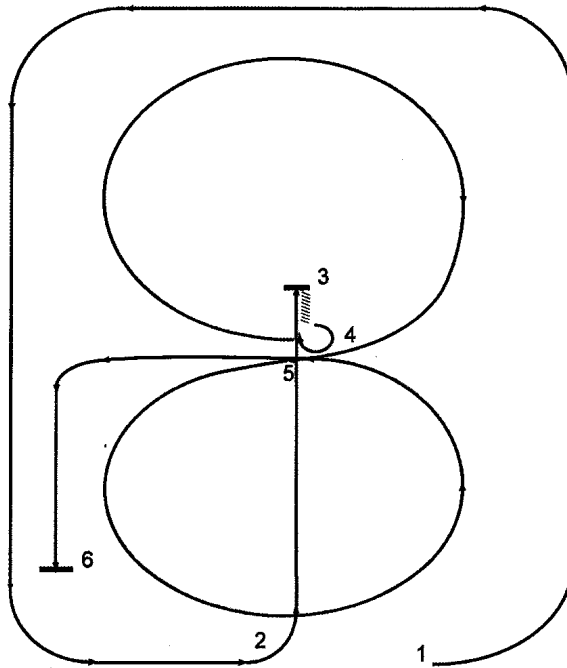

Horsemanship Pattern 2:

1. Circle the arena, on the left lead, at an extended lope.
2. Guide left and lope down the center of the arena with moderate speed.
3. Pass the center of the arena, stop and back to the center.
4. Execute a 3/4 turn to the right and lope a circle, to the right, with moderate speed.
5. Change leads and lope a circle, to the left, with moderate speed. After completing the circle, continue loping on the left lead toward the end of the arena.
6. Stop and pause to show completion of pattern.

Pattern 3

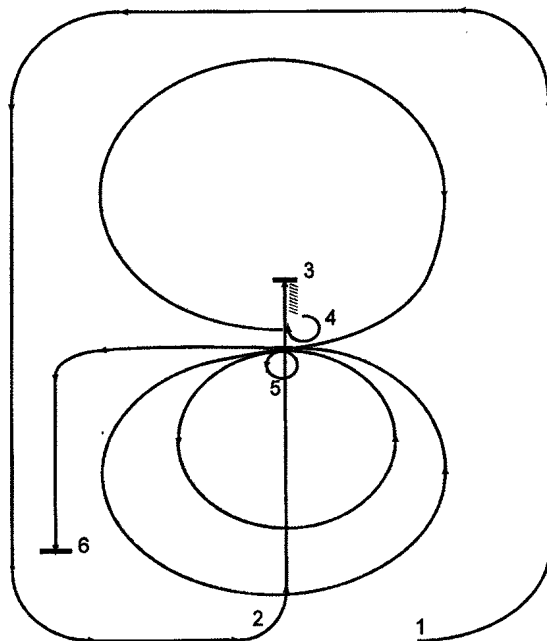

Horsemanship Pattern 3:

1. Circle the arena, on the left lead, at an extended lope.
2. Guide left and lope down the center of the arena with moderate speed.
3. Pass the center of the arena, stop and back to the center.
4. Execute a 3/4 turn to the right and lope a circle, to the right, with moderate speed.
5. Stop in the center, execute a 360 degree turn, to the left. Lope a small slow circle, to the left, followed by a larger, faster circle to the left. At the center of the arena, rate back to the slower speed and continue loping on the left lead toward the end of the arena.
6. Stop and pause to show completion of pattern.

KNOWLEDGE:

The purpose of the following is to evaluate Participant in the following

1. The ability to converse with confidence in all areas.
2. Knowledge of current PRCA and WPRA rules and notables, equine anatomy, equine ailments, equine tack, animal welfare issues and current MRNA, MRA and PRCA sponsors.
3. Awareness and knowledge of current events concerning local, state and world communities.

Written Test:

1. Absolutely no talking will be allowed during testing. Disregard for this rule will result in immediate disqualifications.
2. The Participant will be provided a pen/pencil and should bring nothing with them to the test room.
3. Participants may request reasonable testing accommodations, if needed. Requests must be sent to the National Director-Nevada no less than 30 days prior to first day of the Pageant. These requests will be kept confidential.
4. Test score will be included in the total tabulation for MRN. Copies of tests may be presented to the judges for their reference.

Judged Events:

Panel Interview

Impromptu Speech

Elegance Modeling

Fashion Forward Modeling

Impromptu Question

Round Robin Interview

Horsemanship #1

Horsemanship #2

Horsemanship Interview

Written Test

Wardrobe Guidelines:

- Each Participant must follow the Wardrobe Guidelines.
- NO chaps, spurs, crowns or banners are to be worn during the Pageant, other than those provided by the MRNA Board of Directors.

General Information:

1. **Parents, Friends and Relatives:** The MRNA Board of Directors welcomes and encourages the presence of parents, relatives, and friends during the Pageant. No one will be permitted to fraternize with the Participants or to distract them.
2. The MRNA Board of Directors requests complete cooperation from these supporters during Pageant activities. After the Pageant begins, Participants cannot communicate with parents, relatives, and friends unless authorized by their chaperone. No parents will be allowed in the Participant's rooms during the Pageant.
3. During the Pageant, Participants will be **required** to be together as a group.
4. At no time will parents, relatives or friends of the Participants interfere with the MRN Board of Directors or MRN Pageant Participants.
5. **Some Pageant activities are open only to MRNA Board of Directors, Participants and judges.** If parents, relatives or friends attend closed events, the Participant they support could be eliminated from the Pageant at the MRN Board of Director's discretion.
6. **Only Participants will be allowed in the Horsemanship area before and during the Pageant.** If not adhered to, points can be deducted, or disqualification at judge's discretion.
7. Parents, relatives and friends are responsible for obtaining tickets for all Pageant events and a ticket order form will be posted on our website prior to the Pageant.
8. **Photographs:** Photographs taken of Participants during the Pageant, by Pageant personnel will become property of the MRN Association and may be used for publicity.

NOTICE: only hand held cameras/recording devices may be used at any time during the Pageant.

9. **Sportsmanship:** The MRNA Board of Directors expects each Participant to display good sportsmanship during the Pageant and following the Coronation. Each Participant should be mindful that they are representing the MRN Pageant, the Sport of Professional Rodeo, the Miss Rodeo Nevada Association and Miss Rodeo America, Inc., as well as the State of Nevada. Unsportsmanlike conduct could result in disqualification and affect future eligibility to compete in the MRN Pageant.
10. **Chaperones and security:** The MRNA Board of Directors will select qualified individuals to act as chaperones during the Pageant activities. Upon commencement of the Pageant, Participants are under the jurisdiction of the MRNA Board of Directors for all activities.

Study Information: (suggestions for research, but no limited to)

- The Pro Rodeo Cowboy Association (PRCA) publishes “ProRodeo Sports News” and the ProRodeo Media Guide. For information contact the PRCA at 101 Pro Rodeo Drive, Colorado Springs, Co, 80919. Phone 719- 593-8840. (ProRodeo Cowboy Association (PRCA), current PRCA rules, standings and Participants.)

Visit their website at PRORODEO.COM.

- Current news/events
- Equine knowledge, including care, feeding, diseases and anatomy.
- MRN, MRA/ PRCA Sponsors/manufacturers, etc.
- Knowledge of current events.
- Tack / Horses/horsemanship / Rodeo terminology.
- Animal rights and welfare issues.

Participants will be expected to answer questions interviews, in the written test regarding rodeo in general, the PRCA, and current news/events as part of the Pageant.