



**RULES AND REGULATIONS**  
**March 8<sup>th</sup> – 10th 2019**  
**PAGEANT**

MRNA reserves the right to modify or revise these rules at any time upon reasonable notice

# **RULES AND REGULATIONS**

## **Miss Rodeo America**

The Miss Rodeo America organization and pageant competition selects one young woman to serve as an official spokesperson/ambassador who will promote the Professional Rodeo Cowboys Association, our Agricultural Industry and our Western Traditions. A primary outcome of the process is to provide educational opportunities for these young women who compete in the pageant and to groom young women of today for the leadership positions of tomorrow.

## **Miss Rodeo Nevada**

Miss Rodeo Nevada, hereinafter referred to as MRN, symbolizes the youth of our state. She will represent our state, the sport of rodeo, the state agriculture industry and in so doing, promote our western heritage as she travels throughout Nevada and the country. While spreading good will for her community and her state, she is enjoying one of the richest experiences of her life, and is laying a solid foundation for her future.

The Miss Rodeo Nevada Pageant is held annually to select a young lady who will represent the State of Nevada in the Miss Rodeo America Pageant held every year in conjunction with the Wrangler National Finals Rodeo in Las Vegas, Nevada.

The Miss Rodeo Nevada Board of Directors is responsible for the ceremonies and activities necessary to select the titleholder. The Board of Directors also offers direction, support and assistance to Miss Rodeo Nevada during her reign.

Contestants shall agree to abide by all the Rules and Regulations set forth by the Miss Rodeo Nevada Board of Directors, the Miss Rodeo Nevada Association and Miss Rodeo America, Inc. Breaking any eligibility rules and or regulations will disqualify a contestant from the competition and cause forfeiture of any prizes and/or titles.

Miss Rodeo Nevada is responsible to carry the title proudly; fulfilling duties assigned by the Miss Rodeo Nevada Board of Directors, the Miss Rodeo Nevada Association and Miss Rodeo America, Inc. to the best of her ability.

The Miss Rodeo Nevada Association reserves the right to exercise its governing power where questions may arise throughout the year.

The Miss Rodeo Nevada Board of Directors, by majority vote, has the right to refuse any contestant's application. If a contestant is refused entry into the contest, there will be no appeal process.

# **GENERAL RULES OF THE PAGEANT:**

## **Eligibility:**

1. Contestant will be not less than 19 at the time of the Miss Rodeo Nevada Pageant and shall not have reached the age of 27 prior to December 31<sup>st</sup> of the year she will compete in the Miss Rodeo America Pageant. A copy of a Birth certificate is required.
2. Contestants must be a permanent resident of the State of Nevada for a period of at least six months prior to the Pageant. MRN Elect must maintain that residency throughout her MRN reign. This will be verified by a copy of contestants valid Nevada Driver's License issued at least 6 months prior to Pageant date; or other current proof of residency.
3. Contestant must have a high school diploma or the equivalent of a high school education.
4. Contestant must agree to a Background Check by MRNA and MRA.
5. Must be a natural born female and represent myself as such.
6. Contestants must not be cohabiting with a boyfriend or member of the opposite sex (excluding relatives and/or college/work related roommates) during her reign. (see #18 Title Holder Rules pg. 7)
7. Contestants must be single and never have been married or had a marriage annulled. (see #18 Title Holder Rules pg. 7)
8. Must not be a parent or ever have been a parent. Must never have been pregnant.
9. Contestant must not have been a previous MRN or any other state's similar title holder for any Pageant, or competed or previously competed in the MRA Pageant.
10. Contestant must not have been convicted of any crime or misdemeanor excluding minor traffic offenses.
11. Contestant has never committed or been involved in an act of moral turpitude.
12. Contestant must not have had a title removed for any reason.
13. Contestant must not have engaged in any act, which if made public, would be reasonably likely to cause harm or damage to contestant's reputation or to the goodwill and reputation of the MRN Association. Any concerns about the applicability of this provision should be discussed with a representative of the MRN Association prior to signing the Application Form.

## **Application Rules & Regulations:**

1. Contestant must execute and provide all consents, waivers, agreements, documentation and/or code of conduct as presented as conditions on the due date of the Application and as detailed in the Application Packet. MRNA Board of Directors reserves the right to disqualify any contestant for any non-compliance.
2. Each contestant is required to submit a **NON-Refundable** \$300 entry fee with her application. Checks should be made payable to the MRN Association.
3. All required documents, pictures, and Application must be received no later than the Due Date.
4. Each contestant must submit to the MRNA Board of Directors one 5"x7" vertical color photo. Photo must be head and shoulder pose (no action) in western attire. Western attire will include western blouse, suit or dress, hat and accessories. It is the responsibility of the contestant to arrange their photo session and to submit photos on time with their Application. The photo becomes the property of MRNA and will be used for publicity purposes. (see Application Packet, pg.3)
5. Each contestant must execute a MRN Contract and the Fundraising and Reimbursement Guidelines, as well as any other requested documents (Medical Information, copy of driver's license, etc.), noted on each contestant's Application and must be received no later than the due date.
6. Contestant(s) will be provided horse(s) and tack necessary for the Horsemanship Competition of the Pageant. **The Horsemanship Release Form in the packet MUST be signed and notarized and must be received by due date.**
7. Contestant will be responsible for writing their own biography for the Pageant Program. Details for Biography are on the Checklist of the Application.

**Any contestant not meeting the qualifications set forth above shall be denied the right to compete in the MRN Pageant.**

## **Competition Rules and Regulations:**

1. Judges will be selected by the MRNA Board of Directors.
2. The Pageant will be judged by no less than three judges.
3. All scoring is turned over to an independent Pageant Auditor and only the Auditor will process and seal the results in envelopes that will be opened at the Coronation ceremony. Judges Score Sheets will not be returned.
4. Contestant is required to attend the Pageant Orientation and will provide their own transportation to the host hotel on the first day of the Pageant.

5. Contestant(s) will be provided transportation to and from the Pageant activities. Orientation may consist of the following:
  - a) An opportunity to meet the contestants, their parents and the MRN Board of Directors.
  - b) A description of Pageant activities with the opportunity to ask questions and receive answers about those activities.
  - c) Drawing for the order of the contestant's appearances in all Pageant activities.
6. Contestants must provide their own wardrobe and follow the Wardrobe Guidelines & Dress Code.
7. Contestants will not be permitted to drink alcoholic beverages, use any tobacco, marijuana, illegal substances, inappropriate language or participate in inappropriate internet or social networking behavior at any time during the Pageant or during her reign if chosen as the titleholder.
8. Contestants must conduct themselves in a proper, ladylike manner and portray good moral standards. Actions of un-sportsmanship like conduct will not be tolerated.
9. Contestants, and individuals related to a contestant, may not contact judges before, during, or after the Pageant. Action of this type can result in disqualification of the contestant at the discretion of the MRNA Board of Directors. Any contact with contestant must be through the chaperone.
10. Contestants may not leave the MRN Pageant until the contestants have checked out with the designated MRN Board of Directors Member. Until checked out, all contestants must abide by Pageant rules. Failure to comply with this provision could jeopardize future eligibility, current runner-up status and/or awards.
11. The possession of and/or use of any electronic devices such as cell phones, laptop computers, and/or any devices with internet capabilities are strictly prohibited by contestants during the competition. In case of emergency, all inquiries must go through the chaperone.
12. Contestant's rooms will be assigned by the MRNA Board of Directors.
13. The MRNA Board of Directors reserves the right to alter any rule and has the sole authority over any rule discrepancy. If any rules are altered, contestants will be notified that changes have been made as soon as possible.

## **TITLE HOLDER RULES:**

1. The MRN titleholder must be willing to enter into a contract with the MRN Association and be willing and able to compete in the subsequent year's MRA Pageant, hereinafter referred to as "MRA Pageant."
2. Preparation for the MRA Pageant is extensive and will require a great deal of time and effort on your part. You may find that working full time and/or going to school full time is not an option. Be prepared to scale back one or both activities.
3. MRN may not compete in other Pageants during the year of her reign except MRA.
4. MRN must be willing and able to participate in any rodeo appearances and other special events as requested by the MRN Association.

5. MRN must understand that when she takes the title, the funding for expenses including non-required travel and wardrobe will be her responsibility. The MRN Association is continually soliciting sponsorship to help, but it is still the primary responsibility of the titleholder to fund her reign through personal fundraisers and sponsor solicitation. MRN Association will pay all required travel expenses. Anything else will be titleholder's responsibility.
6. As MRN, you will be required to ride with and take lessons from anyone that the Association arranges time with to better prepare you for the Horsemanship Competition at the MRA Pageant. You will be required to ride as many different horses as possible over the course of your preparation for the MRA Pageant.
7. MRN will work continually with the MRN Association Board of Director's Member designated to monitor appearance compliance. All wardrobe items for the MRA Pageant MUST be approved by the assigned Director.
8. Stringent guidelines will be adhered to in reference to hair, makeup and wardrobe. All guidelines will be established and all outfits are subject to approval prior to any travel. You are always under the microscope as MRN and must ALWAYS dress appropriately. Your job to represent MRN begins the moment you leave your front door until you walk back into it on your return home.
9. Failure to complete reign as MRN or failure to compete in MRA Pageant will constitute a violation of the MRN Contract. The contract will be terminated immediately and shall obligate the titleholder to reimburse MRNA and sponsors for all monies and items won and/or received as MRN including, but not limited to the items enumerated in the MRN Awards and Gifts Contract.
10. There will be no visible tattoos displayed in person or on any social media. If you do have tattoos, they must be covered at all times. There will be no excessive or visible body piercing, with the exception of ears, which are limited to no more than one (1) pairs of earrings to be worn at any time and NEVER above the earlobe. Final determination of acceptance is the MRA National Director - Nevada and the MRN Board of Directors.
11. MRN will not be permitted to drink alcoholic beverages, use any tobacco, marijuana, illegal substances, inappropriate language or participate in inappropriate internet or social networking behavior at any time during the Pageant or during her reign if chosen as the titleholder.
12. MRN will develop a scrap book from the onset of her reign. It is suggested that someone else be designated to assume this role, as it can be very time consuming. The scrapbook will be completed and will be turned in to the MRA Pageant.
13. The MRN Association may add, alter or delete rules as we deem necessary throughout the year. MRN will be required to follow our rules and any changes, deemed necessary by the MRA National Director - Nevada and/or the MRNA Board of Directors, as they may occur.
14. MRN is REQUIRED to communicate with the MRA National Director - Nevada and MRNA Board of Directors. This may be accomplished via e-mail and telephonic transmissions. Mandatory response from MRN is required within a 24 hour time period.
15. MRN is required to report about travels and experiences as MRN via social media and this will be monitored by the Media Director or other person designated by the MRN Association. In addition, the MRN may have a MRN Facebook and/or other social media accounts that the Media Director (or other person designated by MRNA Board of Directors) has access to. These pages will be updated no less than a monthly basis. MRN shall abide by the Guidelines set forth by the Media Director and the MRNA Board of Directors.
16. MRN will not block the Media Director, or any MRNA Board of Directors member from any and all personal social media accounts. \*If at any time any inappropriate items/posts etc. are on the MRN personal social

media accounts, MRN will be required to shut down her accounts until further notice from the Board of Directors. If not done within 24 hours of a written request from the MRA National Director – Nevada or any designated MRNA Board member, MRN will be subject to termination.

17. MRN will have no visible sign of, nor any publicized (including, but not limited to any social media accounts) indication of any status.
18. MRN is responsible for meeting all deadlines and requirements as set by the MRA National Director-Nevada and MRA. Compliance is mandatory. Non-compliance will be cause for termination.
19. It is expressly understood and agreed that in the event MRN does not perform under any part of the Contract, the Rules and Regulations, meet any deadlines or any requirement of the MRA National Director-Nevada, that the MRNA Board of Directors has the right to terminate this contract with written notice to the address of record, sent Certified U.S. mail/overnight courier to the titleholder. This Contract will be immediately, upon the mailing date of the Certified Notice/overnight courier, will be terminated and will be Null and Void and all rights and title will be relinquished.

---

Signature

---

Date

# **PAGEANT DIVISIONS:**

Five (5) divisions come under the judging divisions:

- Personality
- Presentation
- Appearance
- Horsemanship
- Knowledge

See page 17: “Judges Scoring Options” for judging areas per each division. Awards may be given to the contestant scoring highest in the five divisions. It is the decision of the MRNA Board whether prizes are given or not depending on the number of contestants.

The overall winner will be crowned MRN.

## **PERSONALITY:**

**The purpose of this category is to select the contestant who rates highest in:**

1. Intelligence and common sense.
2. Conversational ability and knowledge of the pageant, rodeo, the state agricultural industry, varied situations with an emphasis on correct grammar and enunciation.
3. A sense of humor.
4. Self-confidence, high moral standards, sincerity, and integrity.
5. Self-projection – the ability to project one’s personality in any situation, whether from horseback or on stage, overall appearance, magnetism and eye appeal.
6. Positive outlook on life.
7. Genuine interest in other people and noticeable consideration of others.
8. Conversational ability.
9. Professionalism.
10. Promptness and cooperation. Please note that if a contestant fails to arrive on time for any Pageant event she may be penalized and or disqualified at the MRNA BOARD of Director’s discretion.
11. Maturity.



# **PRESENTATION**

**The purpose of this category is to select the contestant that scores highest in:**

1. The ability to communicate with an audience using correct grammar and enunciation.
2. Shows creativity, personality, initiative, flair.
3. Self-projection on stage, including delivery, voice, manner and use of microphone.
4. Poise, Personality, Appearance, Self-confidence.
5. Sense of humor, delivery, ability to relate to the audience.

# **APPEARANCE:**

**The purpose of this category is to select the contestant who rates highest in:**

1. Attractiveness, charm, radiates self-confidence and maturity.
2. Grooming: this should include meticulous care in neatness, cleanliness in every detail such as complexion, hands, fingernails, makeup, hair, hat, boots and other apparel and age appropriateness in all areas.
3. Posture: This should include carrying oneself straight and tall with self-confidence and poise.
4. Poise and ladylike behavior in every situation: this should include handling every type of situation with grace, style and proper etiquette.
5. Photogenic quality.
6. Western fashion sense: contestants should be aware of what is fashionable and appropriate to western dress. Judges will be looking for versatility and imagination which enhance the contestant's personal features. Attention will be paid to suitability of the outfit to the occasion.
7. Proper fit of clothing: this includes figure - flattering styles altered for a personal fit, if necessary. Properly fitted and shaped hats, which flatter the contestant's face, will be considered. Judges will look for versatility and imagination in the contestant's ability to carry out a "total look." Knowledge of western clothing: this includes the major western wear manufacturers, current and royalty fashion.
8. Trends in western wear industry and western wear sponsors of MRN, MRA and the PRCA.

# **General Rules:**

1. Piercings are not permitted. Pierced earrings may be worn. No more than one (1) pair of earrings may be worn at any time and NEVER above the ear lobe. There will be no visible body piercings at any time. This includes the year of reign also. Final determinate of appropriateness by MRNA Board of Directors.
2. There will be no visible tattoos displayed at any time. If you do have tattoos, they must be covered at all times.
3. Additional information is available in the Wardrobe Guideline.

## **HORSEMANSHIP:**

**The purpose of this category is to select the contestant who rates highest in:**

1. Control of mount, proper arena etiquette, and the way each situation that may occur is handled.
2. Balance, ability, and position of hands, feet, and seat when riding at a reasonable rate of speed for the activity.
3. Precise execution of patterns and understanding the leads.
4. Mounting and dismounting.
5. Confidence, appearance and awareness of audience.
6. Presentation ride (Queens Run/Wave).
7. Knowledge of horsemanship and horse science.
8. Contestant's ability to project her personality to the audience from horseback.

### **General Rules:**

1. The pattern chosen by the judges will be demonstrated.
2. The understanding and skill of the contestant will be judged and not the horse or the equipment.
3. Contestants will be provided horses and western style saddle.
4. There will be two go-rounds of competition, with the order drawn and announced at Orientation. Contestants will ride a different horse for each round of horsemanship competition. Every element of the Horsemanship portion of the Pageant will be scored regardless of execution of set pattern. Failure to execute the set pattern will not constitute disqualification of contestant.

The second go round of competition will consist of Rail Work.

5. Contestants will ride with the tack provided. Any changes required will be determined by the judges. Judges will review tack during the warm-up period and determine suitability of tack to contestant.
6. Contestants will not wear spurs or chaps.
7. Contestants must make sure their hats stay securely on their heads. Failure to do so will result in severe point penalties.
8. Judges may elect to require the contestants to perform any other horsemanship related task they deem relevant.
9. Should an unfair situation occur, at no fault of the contestant, a re-ride will be granted. Re-rides are at the sole discretion of the judges.

10. Judges have the right to ask contestants questions during the Horsemanship Competition. Judges may talk to contestants, or ask horsemanship questions in the arena, on stage, during public appearances and/or during interviews.
11. The following categories may be used for Horsemanship interview topics: Knowledge of tack, horse science (including feeding, grooming, and parts of the horse), professional rodeo, history of rodeo, rodeo terminology, explanation of standard rodeo events, championship rodeo standings, current rodeo issues as well as other horsemanship and rodeo topics deemed important by the judges and/or the MRN Board of Directors.
12. The understanding and skill of the contestant will be judged, NOT the horse or equipment.
13. Contestants will ride with one hand on the reins.
14. Contestants may be asked to carry a flag.
15. Required attire for Horsemanship is in the Wardrobe Guidelines.
16. Other arena work may be requested at the discretion of the MRNA Board of Directors and/or judges.

**Judges may, at their discretion, deduct points if they see or hear trainers and/or parents coaching contestants.**

## Pattern 1

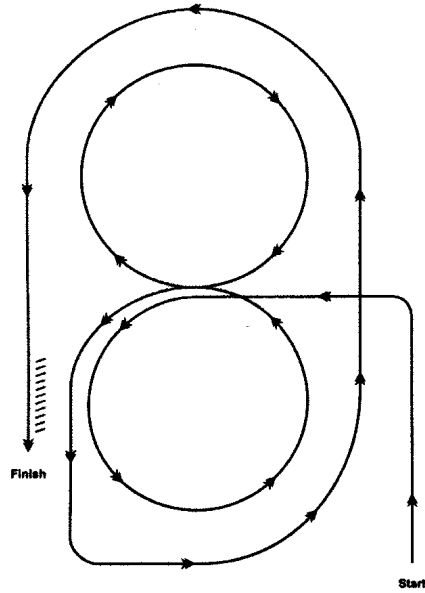

### Horsemanship Pattern 1:

1. Do extended jog along side of arena, then to center
2. Begin lope at center of arena and lope left circle on left lead
3. Change leads at center of arena and lope right circle on right lead
4. Change leads and continue loping around end of arena
5. Once on the straight, increase speed and continue around end of arena
6. Stop and back
7. The Judges Committee reserves the right to make alterations and/or additions to this pattern.

## Pattern 2

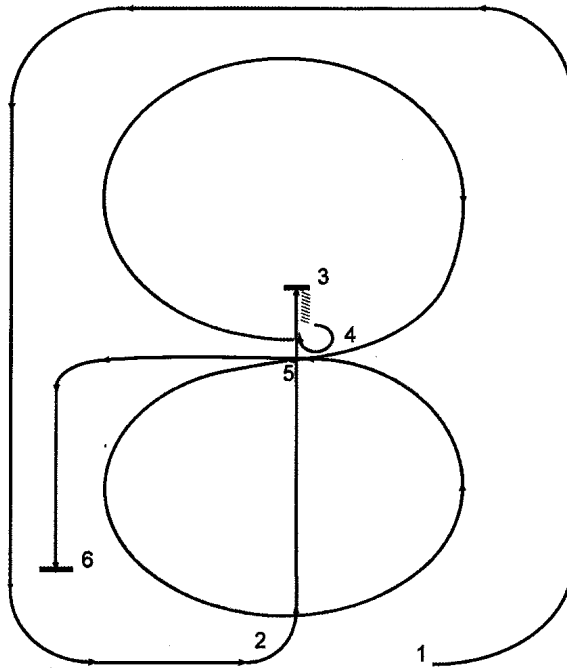

### Horsemanship Pattern 2:

1. Circle the arena, on the left lead, at an extended lope.
2. Guide left and lope down the center of the arena with moderate speed.
3. Pass the center of the arena, stop and back to the center.
4. Execute a 3/4 turn to the right and lope a circle, to the right, with moderate speed.
5. Change leads and lope a circle, to the left, with moderate speed. After completing the circle, continue loping on the left lead toward the end of the arena.
6. Stop and pause to show completion of pattern.

### Pattern 3

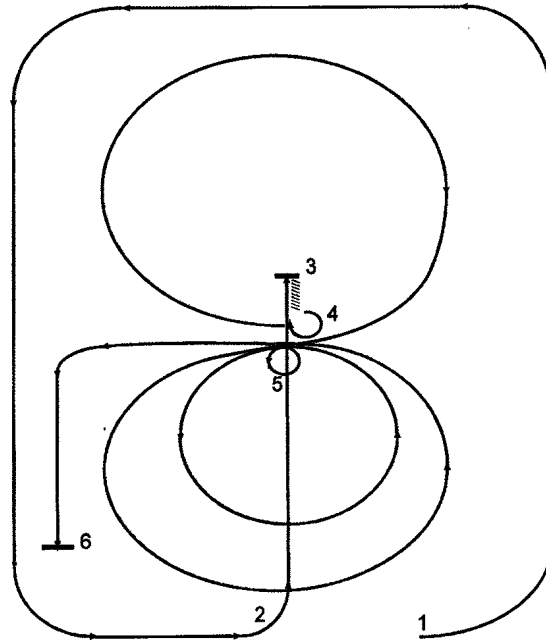

#### Horsemanship Pattern 3:

1. Circle the arena, on the left lead, at an extended lope.
2. Guide left and lope down the center of the arena with moderate speed.
3. Pass the center of the arena, stop and back to the center.
4. Execute a 3/4 turn to the right and lope a circle, to the right, with moderate speed.
5. Stop in the center, execute a 360 degree turn, to the left. Lope a small slow circle, to the left, followed by a larger, faster circle to the left. At the center of the arena, rate back to the slower speed and continue loping on the left lead toward the end of the arena.
6. Stop and pause to show completion of pattern.

## **KNOWLEDGE:**

### **The purpose of this category is to select the contestant who rates highest in:**

1. The ability to converse with confidence in all areas. Contestants should be well studied, understand all areas of rodeo events/terminology, the state agricultural industry and be able to define and have the ability to discuss these areas with confidence.
2. Contestants should be very familiar with current PRCA and WPRA rules and notables, equine anatomy, equine ailments, equine tack, animal welfare issues and current MRNA, MRA and PRCA sponsors.
3. Contestant must be aware and knowledgeable of current events concerning local, state and world communities.
  - ProRodeo Cowboy Association (PRCA), current PRCA rules, standings and contestants.
  - Miss Rodeo Nevada Association.
  - Equine knowledge, including care, feeding, diseases and anatomy.
  - State Agricultural issues/products etc.
  - MRNA/MRA/ PRCA Sponsors/manufacturers, etc.
  - Knowledge of current events.
  - Tack.
  - Horses/horsemanship.
  - Rodeo terminology.
  - Animal rights and welfare issues.

## **General Rules:**

1. Absolutely no talking will be allowed during testing. Disregard for this rule will result in immediate disqualifications.
2. The contestant will be provided a pen/pencil and should bring nothing with them to the test room.
3. Contestants may request reasonable testing accommodations, if needed. Requests must be sent to the National Director-Nevada no less than 30 days prior to first day of the Pageant. These requests will be kept confidential.
4. Test score will be included in the total tabulation for MRN. Copies of tests may be presented to the judges for their reference.

## **SCORING:**

### **Category Winners:**

- a. Personality
- b. Presentation
- c. Appearance
- d. Horsemanship
- e. Knowledge

**The total scores in the categories above shall determine the category winners - Personality, Presentation, Appearance, Horsemanship, and Knowledge. Totals will not necessarily be equal.**

1. All judges' decisions are final.
2. The contestant receiving the highest grand total score for the Pageant shall be crowned MRN.
3. Ties for category winners will be broken by referring back to Judge #1. Judge #1's score will break the tie. If a tie still remains, Judge #2's score will be used and so on until the tie is broken.
4. A tie for MRN will be broken by the Horsemanship scores, i.e., the contestant with the highest score in Horsemanship will receive the higher ranking. No points will be added to or subtracted from a contestant's score.



## Judges Scoring Options/Totals:

Judged Events	Personality	Presentation	Appearance	Horsemanship	Knowledge		Total Per Judge	Total per Contestant (x3 judges)
Panel Interview	40		30		50		120	360
Impromptu Speech	40	30	25				95	285
Elegance Modeling	20	25	50				95	285
Fashion Forward Modeling	20	25	50				95	285
Impromptu Question	40	20	25		20		105	315
Round Robin Interview	40	10	30		50		130	390
Horsemanship #1	20		30	120			170	510
Horsemanship #2	20			120			140	420
Horsemanship Interview	40			50	50		140	420
SubTotal:	280	110	240	290	170		1090	3270
Written Test					100			3370

## Wardrobe Guidelines:

- Each contestant must follow the Wardrobe Guidelines.
- NO chaps, spurs, crowns or banners are to be worn during the Pageant, other than those provided by the MRNA Board of Directors.

## **General Information:**

1. **Parents, Friends and Relatives:** The MRNA Board of Directors welcomes and encourages the presence of parents, relatives, and friends during the Pageant. No one will be permitted to fraternize with the contestants or to distract them.
2. The MRNA Board of Directors requests complete cooperation from these supporters during Pageant activities. After the Pageant begins, contestants cannot communicate with parents, relatives, and friends unless authorized by their chaperone. No parents will be allowed in the contestant's rooms during the Pageant.
3. At the judges' discretion, a contestant may receive point deductions or disqualification for an infraction of any rule.
4. During the Pageant, contestants will be **required** to be together as a group.
5. At no time will parents, relatives or friends of the contestants interfere with the MRN Board of Directors or MRN Pageant contestants.
6. **Some Pageant activities are open only to MRNA Board of Directors, contestants and judges.** If parents, relatives or friends attend closed events, the contestant they support could be eliminated from the Pageant at the MRN Board of Director's discretion.
7. **Only contestants will be allowed in the Horsemanship area before and during the Pageant.** If not adhered to, points can be deducted, or disqualification at judge's discretion.
8. Parents, relatives and friends are responsible for obtaining tickets for all Pageant events and a ticket order form will be posted on our website prior to the Pageant.
9. **Photographs:** Photographs taken of contestants during the Pageant, by Pageant personnel will become property of the MRN Association and may be used for publicity.
10. **Sportsmanship:** The MRNA Board of Directors expects each contestant to display good sportsmanship during the Pageant and following the Coronation. Each contestant should be mindful that they are representing the MRN Pageant, the Sport of Professional Rodeo, the Miss Rodeo Nevada Association and Miss Rodeo America, Inc., as well as the State of Nevada. Unsportsmanlike conduct will result in disqualification and affect future eligibility to compete in the MRN Pageant.
11. **Chaperones and security:** The MRNA Board of Directors will select qualified individuals to act as chaperones during the Pageant activities. Upon commencement of the Pageant, contestants are under the jurisdiction of the MRNA Board of Directors for all activities.

## **Study Information: (suggestions for research, but no limited to)**

1. The Pro Rodeo Cowboy Association (PRCA) publishes “ProRodeo Sports News” and the ProRodeo Media Guide. For information contact the PRCA at 101 Pro Rodeo Drive, Colorado Springs, Co, 80919. Phone 719- 593-8840.
2. Visit their website at PRORODEO.COM.
3. Department of Agriculture State of Nevada - <http://agri.nv.gov/>
4. Current news/events

Contestants will be expected to answer questions regarding rodeo in general, the PRCA, MRN history, State of Nevada Agriculture and current news/events as part of the Pageant.

## **FORMAL COMPLAINT / GRIEVANCE PROCESS:**

Any complaint that is filed in regard to MRN Pageant operations must adhere to the following:

1. All complaints must be submitted in writing.
2. Complaints must include the name, address and daytime phone number of the person filing the complaint.
3. The complaint should include as much detail about the subject as possible in order for appropriate action to be taken.
4. Complaints may be submitted to:  
MRA National Director Chris Lemke – Nevada / President, MRN Association  
1409 Big Valley Lane  
North Las Vegas, NV 89081
5. Complaints must be signed and dated.
6. If a response to the complaint is desired, the letter must indicate so.
7. Any complaints that do not follow the above process will be classified as invalid.

### **MRNA Office follow-up procedure:**

1. All complaints will be reviewed by the MRNA Board of Directors. A MRNA Board of Directors' member will be assigned to research and gather information about the situation. All parties involved will be notified about the complaint and given the opportunity to provide a response.
2. A time frame will be established for the issue to be addressed.
3. The findings will be reported back to the MRNA Board of Directors.
4. The MRNA Board of Directors will vote and determine necessary action to be taken.
5. A MRNA Board of Directors representative will report back to all parties.